

# Back2Back



Back2Back interprets three different types of natural stone.  
 For each of them, the series uses the distinctive features both of the face, the side normally chosen to form the visible floor covering, and of the concealed underside, where exquisite details are revealed.  
 Two sides of the same coin, with different personalities.

"... stone as muse and inspiration..."  
 "... versatile materials, tough surfaces..."  
 "... a selection of slabs for architectural projects..."

Back2Back interpretiert drei verschiedene Natursteine.  
 Die typischen Merkmale der Frontseite, der noblen Sichtseite des Bodenbelags, und der Rückseite, die kostbare verborgene Details offenbart, rücken in den Mittelpunkt.  
 Zwei Seiten einer Medaille mit unterschiedlichen Eigenschaften.

"... Stein als Inspiration..."  
 "... vielseitige Materialien, strapazierfähige Oberflächen..."  
 "... eine Auswahl von Platten für die Planung..."

La collection Back2Back interprète trois différents types de pierre naturelle.  
 Pour chacune d'entre elles, les éléments distinctifs de la face visible, constituée de la partie noble de la pierre, et de la face cachée qui renferme des détails d'une élégance rare, ont été valorisés.  
 Nous avons bel et bien affaire aux deux faces d'une même médaille possédant des identités dissemblables.

"... la pierre devenue muse inspiratrice..."  
 "...des matériaux polyvalents, des surfaces résistantes..."  
 "...une sélection de plaques servant à la conception..."

Back2Back interpreta tres tipos diferentes de piedras naturales.  
 Se ha dado valor a los elementos distintivos de cada una de ellas, tanto de la parte frontal, el área noble que queda visible al pavimentar, como de la parte de atrás, una superficie oculta de la que se revelan preciosos detalles.  
 Son dos caras de la misma medalla con caracteres diferentes.

"... la piedra como musa inspiradora..."  
 "... materiales versátiles, superficies resistentes..."  
 "... una selección de losas para proyectar..."

Back2Back по своему интерпретирует три разных типа натурального камня.  
 Для каждого из них подчеркиваются характерные черты как на лицевой и обычно находящейся на поверхности части, так и на невидимой тыльной стороне, которая также открывает интересные детали.  
 Две стороны одной и той же плиты, но с разным характером.

"... камень становится музой-вдохновительницей..."  
 "... универсальные материалы, прочные поверхности..."  
 "... ассортимент плит для создания проектов..."

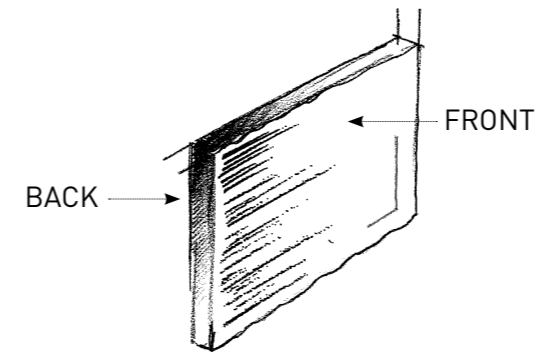

**Back2Back interpreta tre tipologie di pietre naturali differenti.**

Per ognuna sono stati valorizzati gli elementi distintivi sia del fronte, della parte nobile normalmente esposta a pavimento, che del retro, con la parte nascosta che rivela dettagli preziosi.  
 Due facce della stessa medaglia con caratteri differenti.

"... la pietra come musa ispiratrice..."

"... materiali versatili, superfici resistenti..."

"... una selezione di lastre per progettare..."



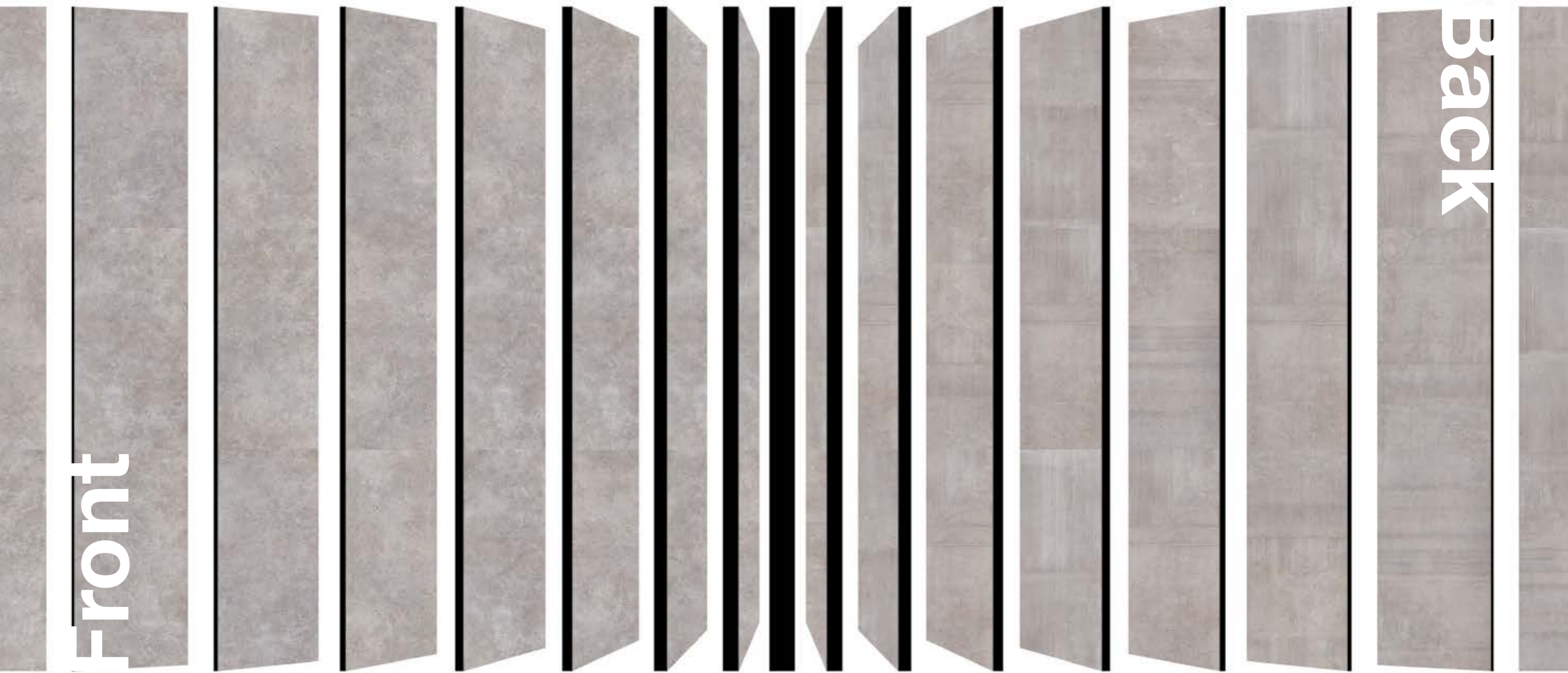

# SECTION

# Back2Back Spaces

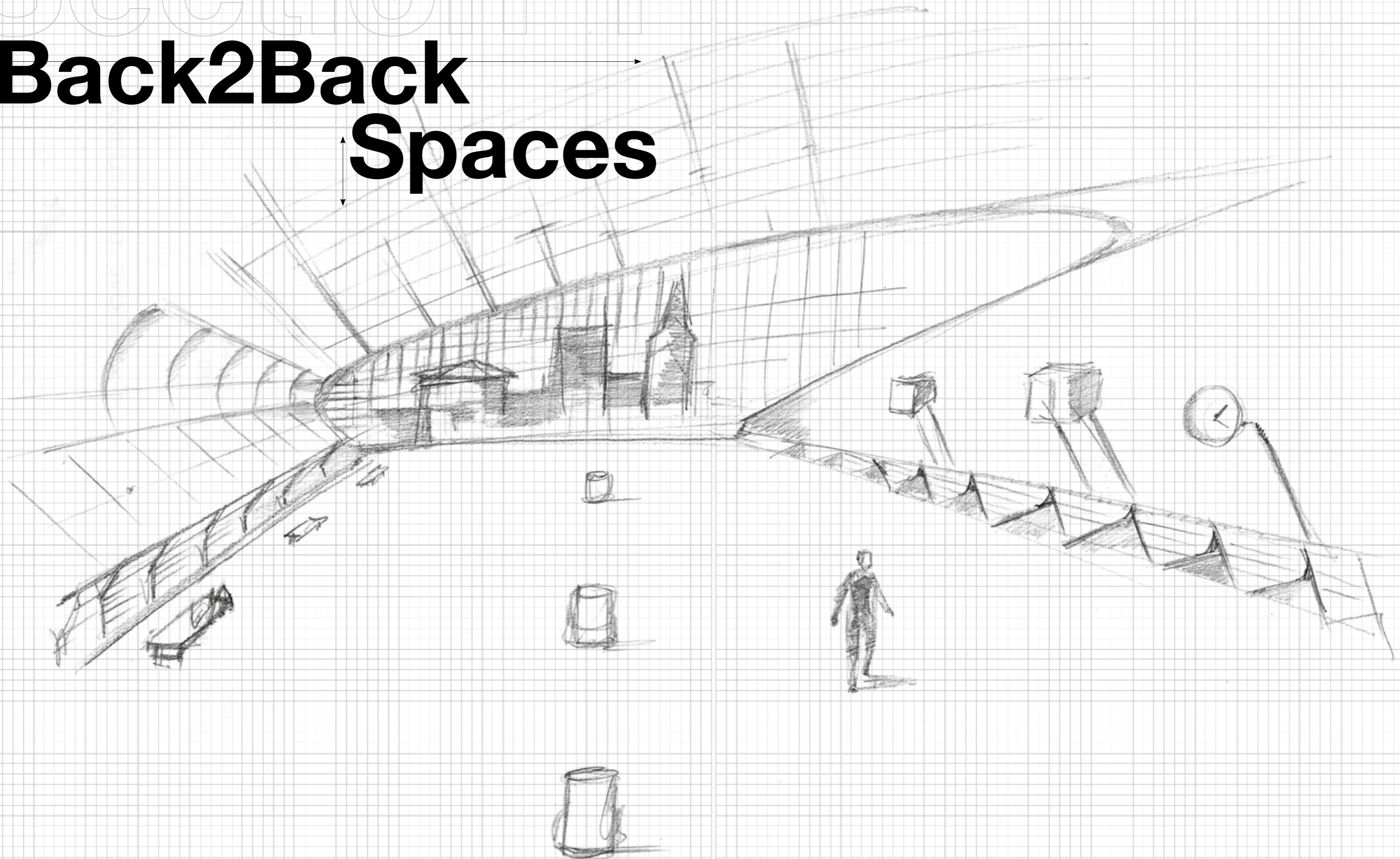

# White

BACK WHITE NAT. RETT.  
60x120 - 23<sup>5</sup>/<sub>8</sub>"x47<sup>1</sup>/<sub>4</sub>"

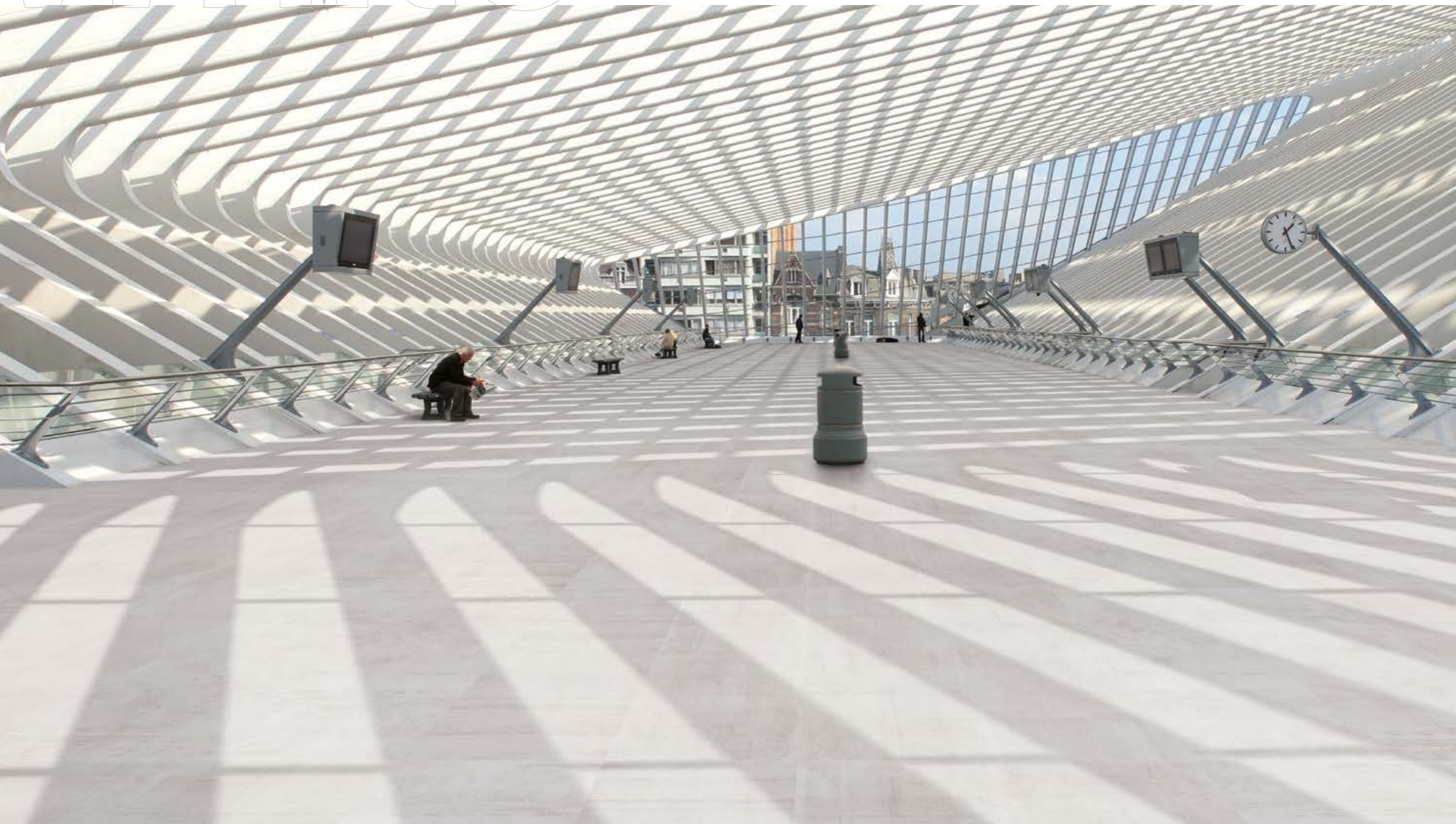
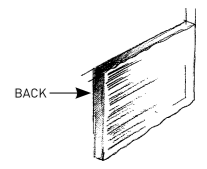

# White Back

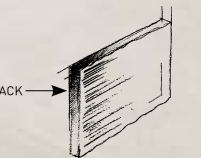
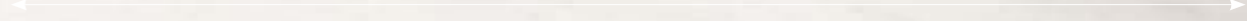

# White

FRONT FALL WHITE LAPP. RETT.  
60x120 - 23<sup>5</sup>/<sub>8</sub>"x47<sup>1</sup>/<sub>4</sub>"

BACK WHITE NAT. RETT.  
60x120 - 23<sup>5</sup>/<sub>8</sub>"x47<sup>1</sup>/<sub>4</sub>"

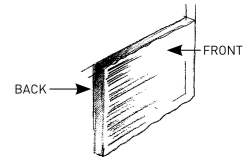

# Front lappato

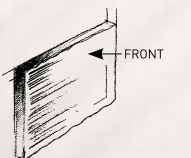



# White

BLEND FRONT/BACK WHITE NAT. RETT.  
20x120 - 7<sup>7/8</sup>"x47<sup>1/4</sup>"

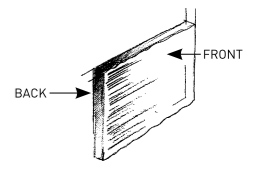

# White Blend

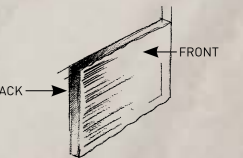

# oeidae

BACK BEIGE NAT. RETT.  
60x120 - 23<sup>5</sup>/<sub>8</sub>" x 47<sup>1</sup>/<sub>4</sub>"

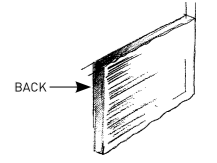

# Back beige

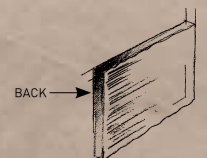

FRONT POWDER BEIGE NAT. RETT.  
60x120 - 23<sup>5</sup>/<sub>8</sub>" x 47<sup>1</sup>/<sub>4</sub>"

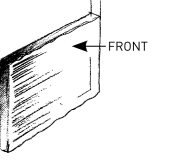

# Front natural

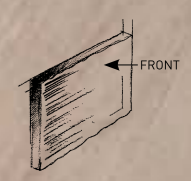

# beige

BLEND FRONT/BACK BEIGE NAT. RETT.  
20x120 - 7<sup>7/8</sup>"x47<sup>1/4</sup>"

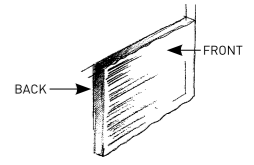

# Blend

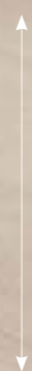

beigge

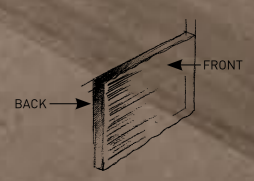



# dreu

BACK GREY NAT. RETT.  
60x120 - 23<sup>5/8</sup>"x47<sup>1/4</sup>"

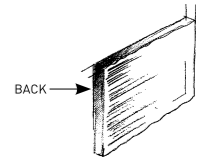

# g r o Back

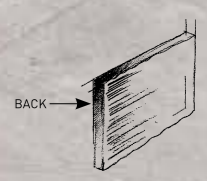

FRONT MINERAL GREY NAT. RETT.  
60x120 - 23<sup>5/8</sup> x 47<sup>1/4</sup>"

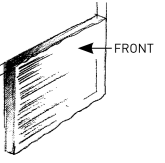

# Front natural

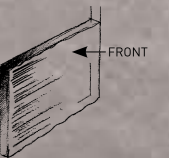

BLEND FRONT/BACK GREY NAT. RETT.  
20x120 - 7<sup>7/8</sup>"x47<sup>1/4</sup>"

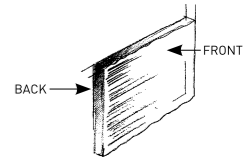

# gloss Blend

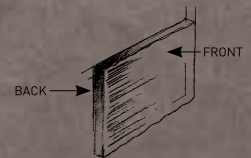

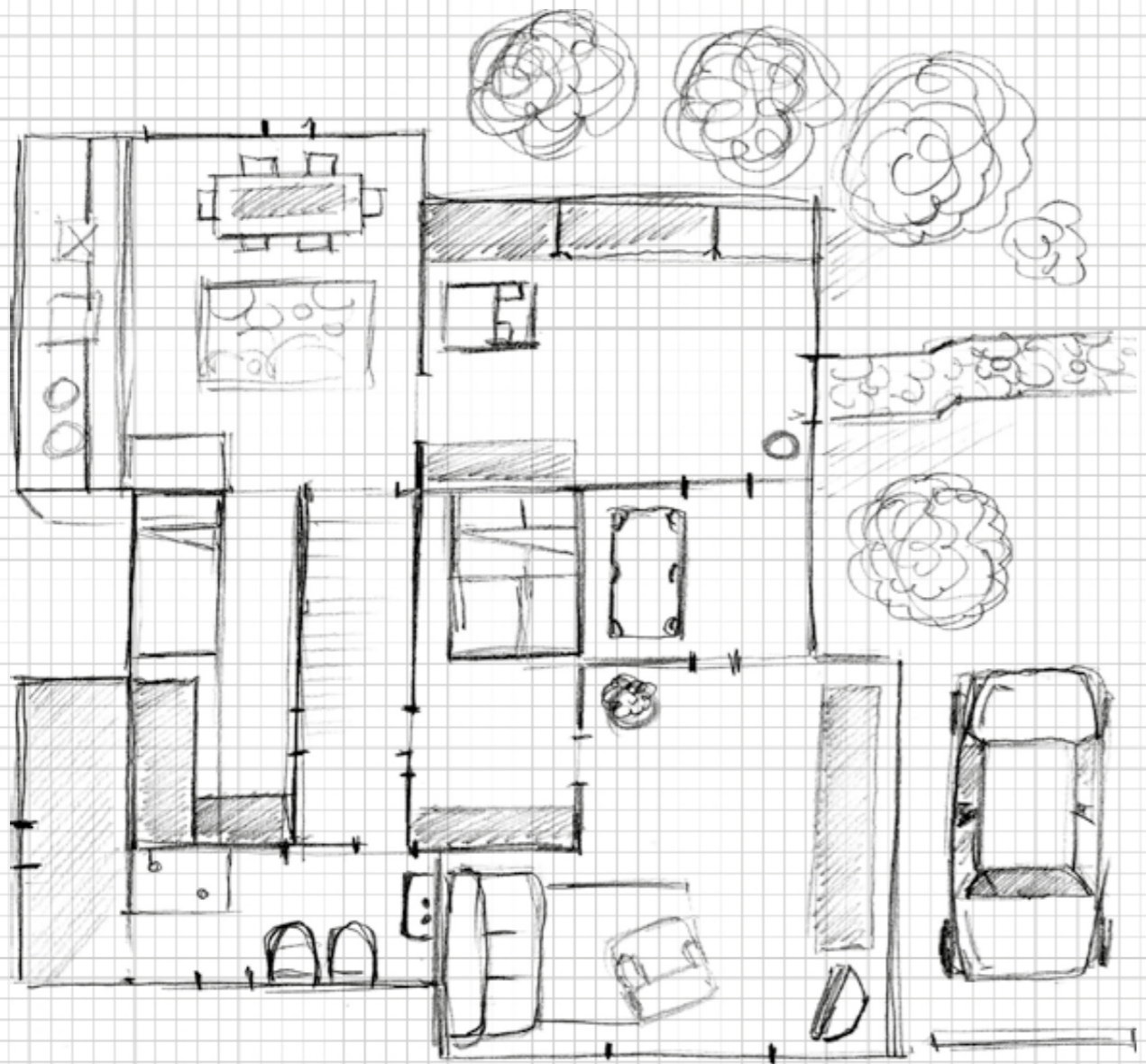

# Section 2

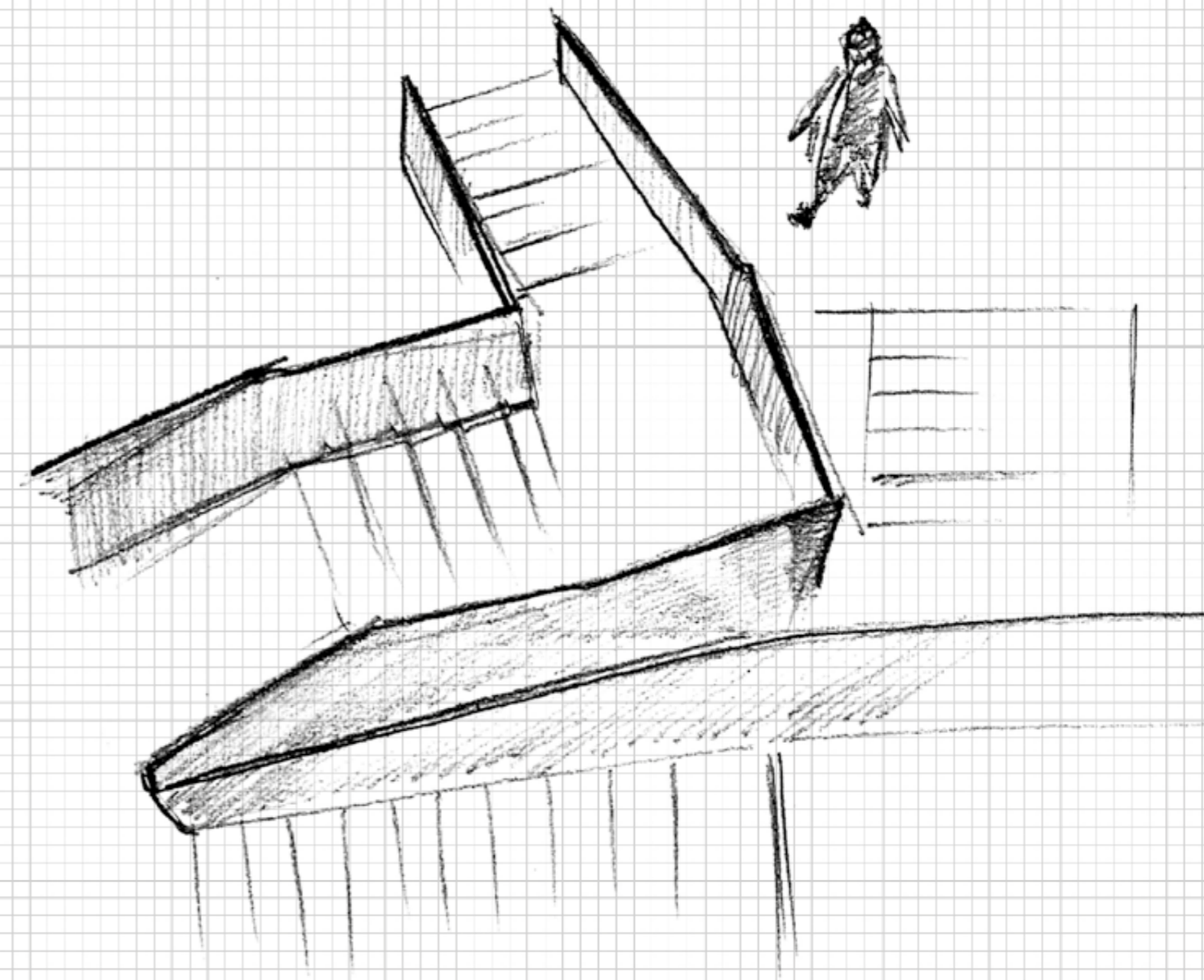

# Back2Back Real loft

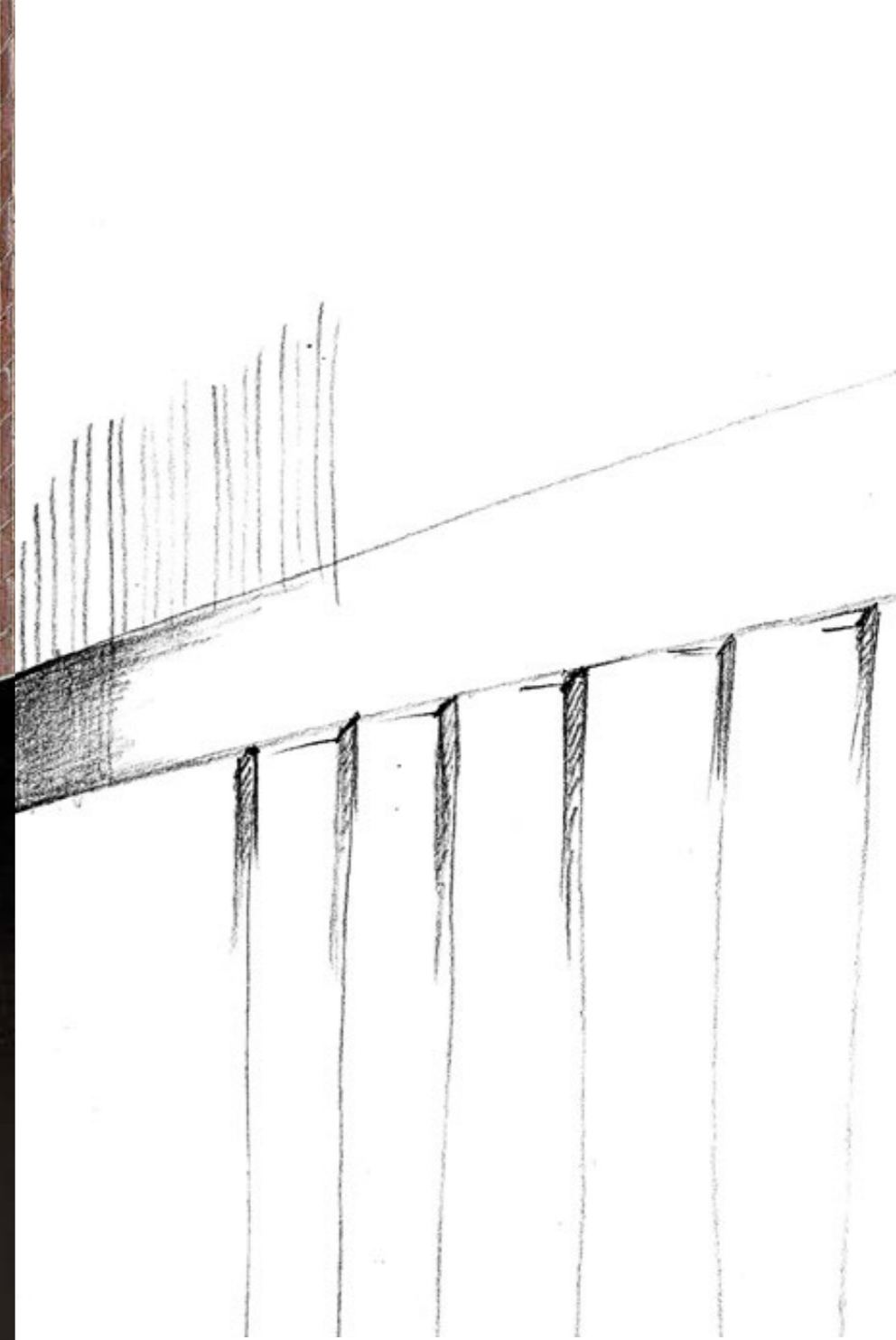

BACK GREY RETT.  
60x120 - 23<sup>5/8</sup> x 47<sup>1/4</sup>"

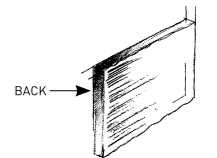



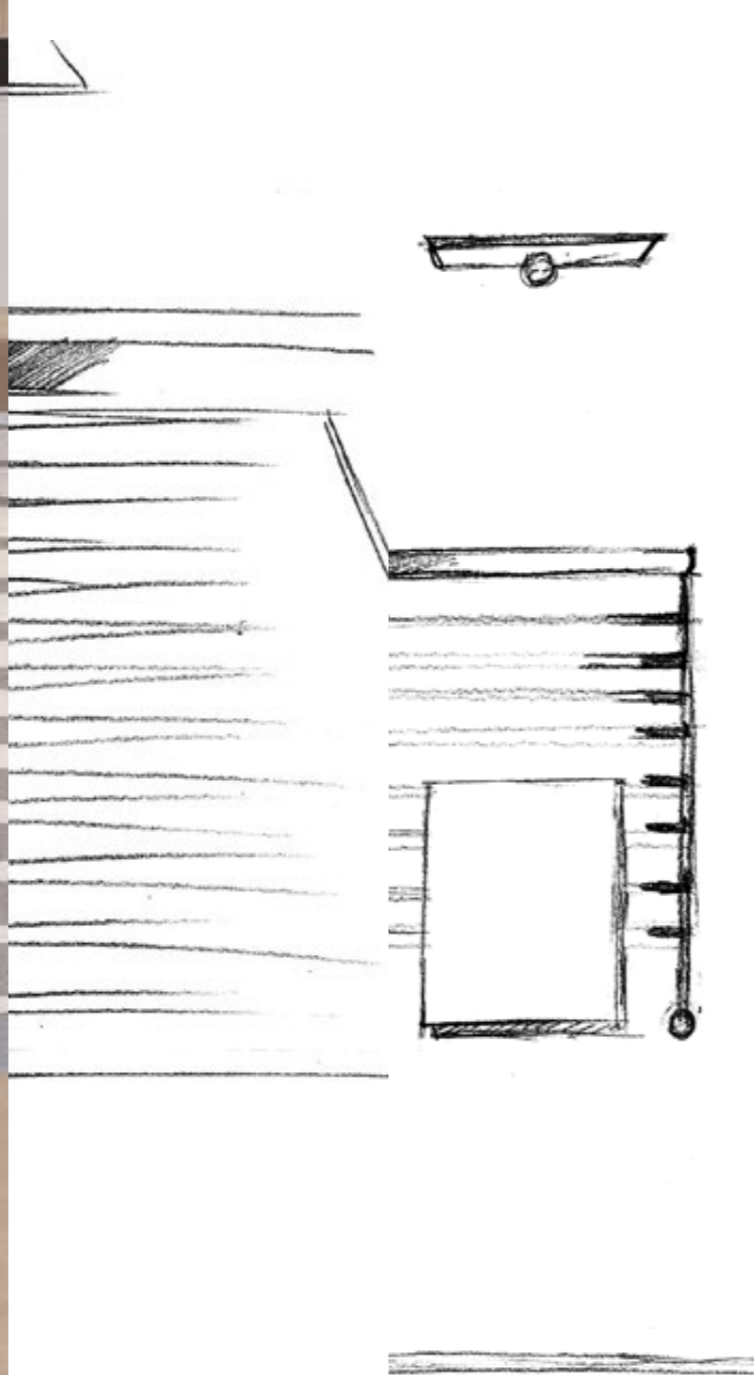

BACK BEIGE NAT. RETT.  
60x60 - 23<sup>5/8</sup>"x23<sup>5/8</sup>"

FRONT POWDER  
BEIGE NAT. RETT.  
60x60 - 23<sup>5/8</sup>"x23<sup>5/8</sup>"

FRONT POWDER  
BEIGE NAT. RETT.  
60x60 - 23<sup>5/8</sup>"x23<sup>5/8</sup>"

MOSAICO  
BACK2BACK BEIGE  
30x30 - 11<sup>13/16</sup>"x11<sup>13/16</sup>"

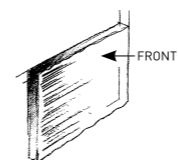
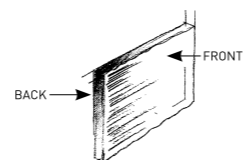

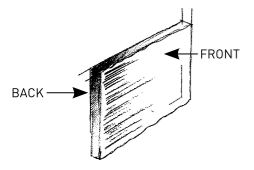
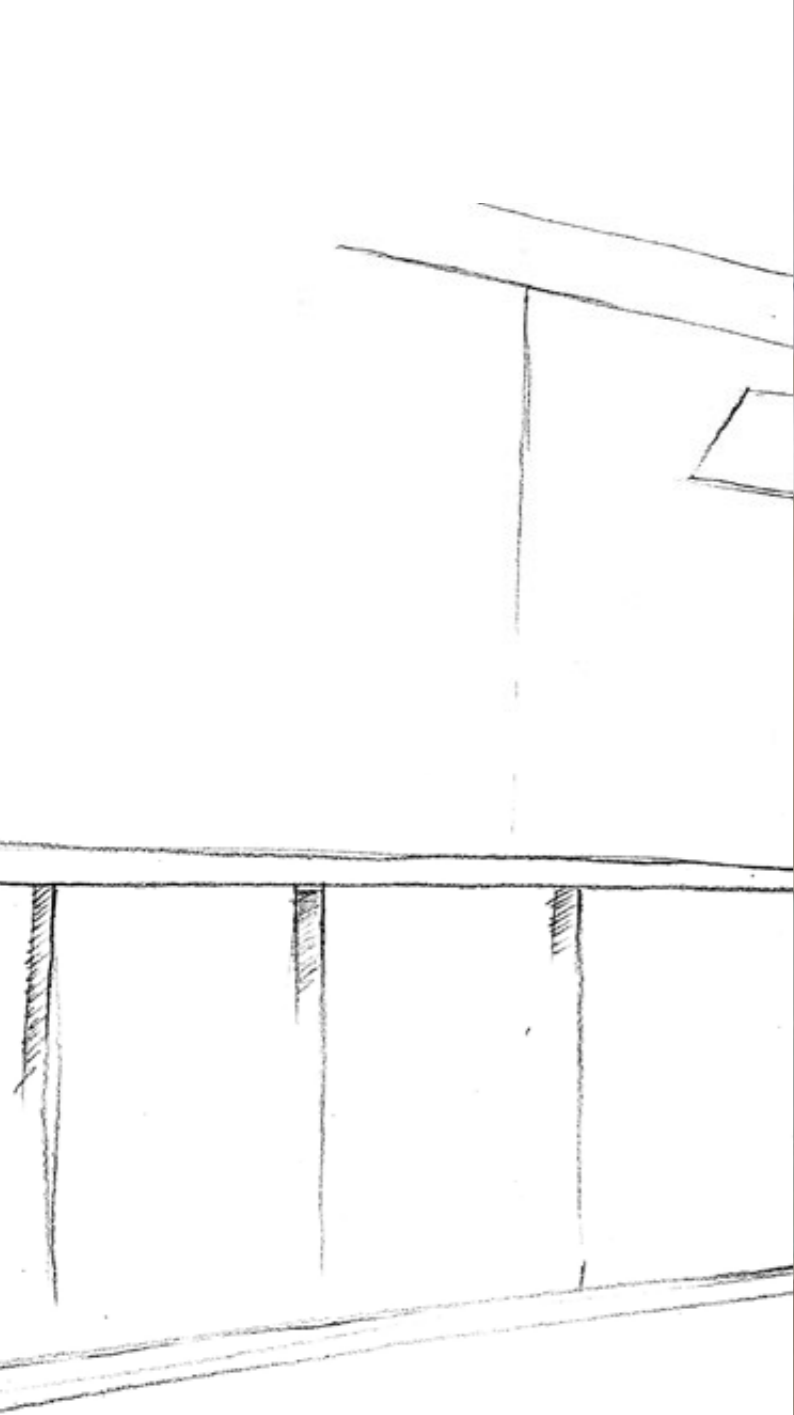

BLEND FRONT/BACK BEIGE NAT. RETT.  
20x120 - 7<sup>7</sup>/<sub>8</sub>" x 47<sup>1</sup>/<sub>4</sub>"

# Forma e sostanza

## ISPIRAZIONE:

Enormi lastre di pietra. Il fronte perfetto, pulito, disegnato; il retro polveroso, irregolare, segnato dalle lame degli utensili a taglio.

## PRODOTTO:

Il fronte della lastra evidenzia le stratificazioni e le sedimentazioni minerarie, la grafica è nitida, precisa e pulita.

Il retro della stessa, appare sbiancato, impreciso nei dettagli grafici, minimale nel disegno.

Ogni colorazione presenta una grafica differente sia per il fronte che per il retro.

Il colore grigio interpreta la pietra moka brown proveniente dal Nord Africa, il beige la pietra star wood del Brasile, il bianco un'agata uruguiana reinterpretata.

## SUPERFICIE:

Le 3 superfici di Back2Back sono state studiate e testate per garantire la massima resa tecnica ed estetica del prodotto.

Retro: conserva i segni del taglio sega e le imperfezioni causate dal trascinarsi delle lastre.

Fronte naturale: la grafica e la struttura tridimensionale compenetrano in modo da garantire un effetto estetico estremamente realistico e naturale.

Fronte lappato: la lappatura lucida segue la reale struttura della pietra.

## GRAFICA:

Per ottenere la massima naturalezza, abbiamo fotografato ad alta risoluzione e riprodotto con tecnologia full HD una ventina di grandi lastre di pietra naturale.

Questa operazione è stata fatta sia per il "Front" che per il "Back".

Ergon ama le sfide: in Back2Back genio e materia si fondono per divenire progetto.

## FORME ET SUBSTANCE

### Inspiration

D'énormes plaques en pierre, dont la face visible est parfaite, propre et minutieusement dessinée et dont la face cachée, poussiéreuse et irrégulière, porte encore les traces des lames des outils de découpe, ont servi de base à l'élaboration de la collection.

### Produit

La face visible des plaques en pierre fait ressortir les stratifications et les sédimentations minérales. Le graphisme est précis et parfaitement défini. La face cachée apparaît, quant à elle, comme lessivée et se distingue par des détails graphiques imprécis et un dessin sobre. Chaque coloris présente un graphisme différent tant pour la face visible que cachée.

La couleur grise renvoie à la pierre moka brown provenant de l'Afrique du Nord, la couleur beige à la pierre star wood du Brésil et la couleur blanche à une agate uruguayenne revisitée.

### Surface

Les 3 surfaces de Back2Back ont été étudiées et testées afin de garantir le meilleur rendu technique et esthétique du produit. Face cachée : elle conserve les signes de la découpe du bois à la scie et les imperfections provoquées par le déplacement des plaques. Face visible naturelle : le graphisme et la structure

tridimensionnelle se fondent offrant un effet esthétique extrêmement réaliste et naturel. Face visible semi polie : le polissage brillant suit la structure réelle de la pierre.

### Graphisme

Afin d'obtenir un effet naturel optimal, nous avons photographié, selon un procédé haute résolution, et reproduit, en faisant appel à une technique Full HD, une vingtaine de grandes plaques en pierre naturelle. Cette opération a été réalisée aussi bien pour la face cachée que visible des plaques.

Ergon aime relever les défis: dans Back2Back, génie et matière se fondent à merveille pour devenir une réalité tangible.

## FORM AND SUBSTANCE

### Inspiration:

Huge stone slabs. The flawless, smooth face with its fine patterning; the dusty, rough underside, with the marks left by the cutting tools.

### Product:

In the face of the slab, the stratified, sedimented minerals are highlighted, with clear, precise patterning. The underside looks faded, its patterning and details minimal and confused.

Each colour has a different patterning on both the face and the underside.

Grey is inspired by moka brown stone from North Africa, beige by star wood stone from Brazil, and white is a reinterpreted Uruguayan agate.

### Surfaces:

Back2Back's 3 surfaces have been developed and tested to ensure that the product delivers the best in terms of technical properties and appearance.

Back: features the marks left by sawing and flaws caused when slabs are dragged across the ground

Natural front: the patterning and three-dimensional structure intermingle to provide an extremely realistic, natural effect.

Honed front: the glossy honed finish follows the real structure of the stone.

### Patterning:

For the most natural effect, we took high-resolution photographs of twenty or so large slabs of natural stone, and reproduced them in full HD.

This procedure was carried out for both the front and the back.

Ergon loves challenges: in Back2Back genius and matter merge to become design.

## FORM UND SUBSTANZ

### Inspiration:

Riesengroße Steinplatten. Die Frontseite perfekt mit sauberer Zeichnung; die Rückseite stumpf, unregelmäßig, behaftet mit den Spuren der Schneidwerkzeuge.

### Produkt:

Die Frontseite der Platte zeigt die mineralischen Schichtungen und Ablagerungen. Die Zeichnung ist klar, präzise und sauber. Ihre Rückseite erscheint gebleicht, mit unscharfen Musterungen und einer sparsamen Zeichnung. Jede Farbe weist ein unterschiedliches Muster auf der Front- und Rückseite auf.

Die Farbe Grau interpretiert den Naturstein Moka Brown aus Nordafrika, Beige die Steinsorte Star Wood aus Brasilien und Weiß einen Achat aus Uruguay.

### Oberfläche:

Die drei Oberflächen von Back2Back wurden so konzipiert, dass die besten technischen und optischen Eigenschaften des Produkts gewährleistet sind.

Rückseite: Bewahrt die Sägeschneidspuren und die Verkratzungen infolge des Schiebens der Platten.

Natürliche Frontseite: Die Zeichnung und die Tiefenoptik schaffen eine äußerst realistische, natürliche Ausstrahlung.

Geläppte Frontseite: Die anpolierte Läppung folgt der tatsächlichen Steinstruktur.

### Zeichnung:

Für eine möglichst natürliche Ausstrahlung haben wir rund zwanzig große Natursteinplatten mit hoher Auflösung fotografiert und mit Full HD-Technik reproduziert.

Das galt sowohl für die Front- wie für die Rückseite.

Ergon sucht stets nach neuen Wegen: In Back2Back verbinden sich Geist und Materie zu einem Projekt.

## FORMA Y SUBSTANCIA

### Inspiración:

Enormes losas de piedra. La parte frontal perfecta, limpia, dibujada; la de atrás pulverulenta, irregular, marcada por las cuchillas de las herramientas de corte.

### Producto:

La parte frontal de losa muestra las estratificaciones y sedimentaciones minerales; el diseño gráfico es neto, preciso, limpio. La parte de atrás ha empaldecido, los detalles gráficos se ven borrosos, el diseño es minimal. Cada coloración presenta un diseño gráfico diferente, tanto por delante como por detrás.

El color gris interpreta la piedra moka brown procedente del norte de África, el beige la piedra star wood de Brasil, el blanco una agata uruguaya reinterpretada.

### Superficie:

Las tres superficies de Back2Back se han estudiado y probado para garantizar el máximo rendimiento técnico y estético del producto.

Parte de atrás: conserva las huellas del corte de la sierra y las imperfecciones ocasionadas en las losas al ser arrastradas.

Parte frontal natural: el diseño gráfico y la estructura tridimensional se compenetrano para garantizar un efecto estético extraordinariamente realista y natural.

Parte frontal esmerilada: el esmerilado brillante sigue la estructura real de la piedra.

### Diseño gráfico:

Para lograr la máxima naturalidad hemos fotografiado a alta resolución y reproducido con tecnología full HD una veintena de grandes losas de piedra natural.

Esta operación se ha realizado tanto con la superficie como con la parte de atrás.

Ergon ama los desafíos: en Back2Back genio y materia se funden para convertirse en proyecto.

## ↑ Forma и сутьность

### Вдохновение:

Очень крупные каменные плиты. У них безупречная лицевая сторона, чистая, словно вычерченная, а тыльная - пыльная, неровная, искаженная полотном режущего инструмента.

### Продукт:

Лицевая сторона плиты показывает минеральные расслоения и отложения, графика - четкая, точная и чистая.

Тыльная же сторона выглядит бледно, с размытыми графическими деталями, едва заметной текстурой.

Каждый цвет предлагает разную графику как для лицевой, так и для тыльной стороны.

Серый цвет воспроизводит камень тока brown из Северной Африки, бежевый цвет - бразильский камень star wood, а белый цвет -

это новое толкование уругвайского агата.

### Поверхность:

3 поверхности коллекции Back2Back были созданы и испытаны для обеспечения максимального технического и эстетического результата продукта.

Тыльная сторона: сохраняет следы распила и неровности, образующиеся при перетаскивании плит.

Натуральная лицевая сторона: графика и трехмерная текстура переплетаются друг с другом, гарантируя очень реалистичный и натуральный эффект.

Притертая лицевая сторона: глянцевая притирка следует реальной структуре камня.

### Графика:

Для обеспечения максимальной натуральности мы сняли с высоким разрешением и воспроизвели при помощи технологии full HD двадцать крупных плит из натурального камня. Такую операцию мы выполнили как для лицевой, так и для тыльной стороны.

Ergon любит принимать новые вызовы: в коллекции Back2Back гениальность и материя сливаются воедино и превращаются в проект.



**Fall White**  
Front

**Powder Beige**  
Front

**Mineral Grey**  
Front

**Back White**  
Back

**Back Beige**  
Back

**Back Grey**  
Back



60x120 (23<sup>5/8</sup>"x47<sup>1/4</sup>") **FRONT**  
**E72T** 986H0R FALL WHITE NAT. RETT. ● 89  
**E73F** 986H1R POWDER BEIGE NAT. RETT. ● 89  
**E72V** 986H8R MINERAL GREY NAT. RETT. ● 89  
**E72S** 986H0P FALL WHITE LAPP. RETT. ● 96  
**E4ZF** 986H1P POWDER BEIGE LAPP. RETT. ● 96  
**E72U** 986H8P MINERAL GREY LAPP. RETT. ● 96

60x60 (23<sup>5/8</sup>"x23<sup>5/8</sup>") **FRONT**  
**E1TZ** 606H0R FALL WHITE NAT. RETT. ● 73  
**E1UY** 606H1R POWDER BEIGE NAT. RETT. ● 73  
**E1U1** 606H8R MINERAL GREY NAT. RETT. ● 73  
**E1TY** 606H0P FALL WHITE LAPP. RETT. ● 83  
**E1UX** 606H1P POWDER BEIGE LAPP. RETT. ● 83  
**E1U0** 606H8P MINERAL GREY LAPP. RETT. ● 83

30x60 (11<sup>13/16</sup>"x23<sup>5/8</sup>") **FRONT**  
**E1U4** 636H0R FALL WHITE NAT. RETT. ● 66  
**E1V0** 636H1R POWDER BEIGE NAT. RETT. ● 66  
**E1U5** 636H8R MINERAL GREY NAT. RETT. ● 66

20x120 (7<sup>7/8</sup>"x47<sup>1/4</sup>") **FRONT + BACK**  
**E1ZU** 548H0R BLEND FRONT/BACK WHITE NAT. RETT. ● 95  
**E1ZV** 548H1R BLEND FRONT/BACK BEIGE NAT. RETT. ● 95  
**E1ZW** 548H8R BLEND FRONT/BACK GREY NAT. RETT. ● 95

60x120 (23<sup>5/8</sup>"x47<sup>1/4</sup>") **BACK**  
**E72Q** 985H0R BACK WHITE NAT. RETT. ● 89  
**E73E** 985H1R BACK BEIGE NAT. RETT. ● 89  
**E72R** 985H8R BACK GREY NAT. RETT. ● 89

60x60 (23<sup>5/8</sup>"x23<sup>5/8</sup>") **BACK**  
**E1TW** 605H0R BACK WHITE NAT. RETT. ● 73  
**E1UW** 605H1R BACK BEIGE NAT. RETT. ● 73  
**E1TX** 605H8R BACK GREY NAT. RETT. ● 73

30x60 (11<sup>13/16</sup>"x23<sup>5/8</sup>") **BACK**  
**E1U2** 635H0R BACK WHITE NAT. RETT. ● 66  
**E1U3** 635H1R BACK BEIGE NAT. RETT. ● 66  
**E1U3** 635H8R BACK GREY NAT. RETT. ● 66

# Formati

SIZES / FORMATS / FORMATE / TAMAÑOS / ФОРМАТЫ

Front + Back = Blend°



20x120 (7<sup>7/8</sup>"x47<sup>1/4</sup>")  
**E1ZU 548H0R**  
 BLEND FRONT/BACK  
 WHITE NAT. RETT. ● 95



20x120 (7<sup>7/8</sup>"x47<sup>1/4</sup>")  
**E1ZV 548H1R**  
 BLEND FRONT/BACK  
 BEIGE NAT. RETT. ● 95



20x120 (7<sup>7/8</sup>"x47<sup>1/4</sup>")  
**E1ZW 548H8R**  
 BLEND FRONT/BACK  
 GREY NAT. RETT. ● 95

° Miscela pronta in scatola - Ready mixed in the box - Mélange prêt à poser vendu par boîte  
 Fertige Mischung im Karton - Mezcla lista en caja - Готовая смесь в коробке

# Pezzi speciali

TRIMS / PIECES SPECIALES / FORMTEILE  
 PIEZAS ESPECIALES / СПЕЦИАЛЬНЫЕ ИЗДЕЛИЯ

## Front

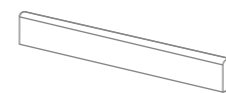
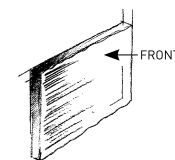

**BATTISCOPA - SKIRTING**  
 7,5x60 (2<sup>15/16</sup>"x23<sup>5/8</sup>")  
 Pcs. Box 15 - Ml. x Box 9  
**E1YE 876H0R** FALL WHITE NAT. RETT. ● 16  
**E1YG 876H1R** POWDER BEIGE NAT. RETT. ● 16  
**E1YJ 876H8R** MINERAL GREY NAT. RETT. ● 16  
**E1YD 876H0P** FALL WHITE LAPP. RETT. ● 18  
**E1YF 876H1P** POWDER BEIGE LAPP. RETT. ● 18  
**E1YH 876H8P** MINERAL GREY LAPP. RETT. ● 18

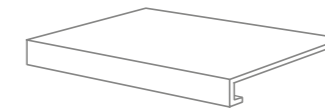

**GRADONE - STEP**  
 33x60x3,2x3,2 (12<sup>15/16</sup>"x23<sup>5/8</sup>"x1<sup>1/4</sup>"x1<sup>1/4</sup>")  
 Pcs. Box 4 - Ml. x Box 2,40  
**E85T CR6H0RG** FALL WHITE NAT. RETT. ● 89  
**E85V CR6H1RG** POWDER BEIGE NAT. RETT. ● 89  
**E85X CR6H8RG** MINERAL GREY NAT. RETT. ● 89  
**E85S CR6H0PG** FALL WHITE LAPP. RETT. ● 92  
**E85U CR6H1PG** POWDER BEIGE LAPP. RETT. ● 92  
**E85W CR6H8PG** MINERAL GREY LAPP. RETT. ● 92

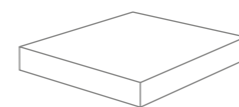

**ANGOLARE DX / SX - CORNER TILE DX / SX**  
 33x33x3,2x3,2 (12<sup>15/16</sup>"x12<sup>15/16</sup>"x1<sup>1/4</sup>"x1<sup>1/4</sup>")  
 Pcs. Box 2 - Ml. x Box 0,66  
**E85D A6H0RCD / E85E A6H0RCS** FALL WHITE NAT. RETT. ● 96  
**E85H A6H1RCD / E85J A6H1RCS** POWDER BEIGE NAT. RETT. ● 96  
**E85M A6H8RCD / E85N A6H8RCS** MINERAL GREY NAT. RETT. ● 96  
**E85A A6H0PCD / E85C A6H0PCS** FALL WHITE LAPP. RETT. ● 100  
**E85F A6H1PCD / E85G A6H1PCS** POWDER BEIGE LAPP. RETT. ● 100  
**E85K A6H8PCD / E85L A6H8PCS** MINERAL GREY LAPP. RETT. ● 100

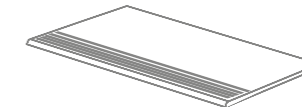

**GRADINO - STAIR TREAD**  
 33x60 (12<sup>15/16</sup>"x23<sup>5/8</sup>")  
 Pcs. Box 6 - Ml. x Box 3,60  
**E1Y7 716H0RG** FALL WHITE NAT. RETT. ● 56  
**E861 716H1RG** POWDER BEIGE NAT. RETT. ● 56  
**E1Y8 716H8RG** MINERAL GREY NAT. RETT. ● 56

# Decorati

DECORS / DECORS / DEKORE / DECORADOS / ДЕКОРЫ

Mosaico Back2Back\*  
 Tessera - Chip 2,8x2,8 (1<sup>1/8</sup>"x1<sup>1/8</sup>")

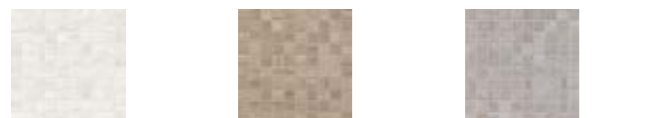

30x30 (11<sup>13/16</sup>"x11<sup>13/16</sup>")  
**E1VC I305H0** WHITE NAT. ● 138  
**E1VD I305H1** BEIGE NAT. ● 138  
**E1VE I305H8** GREY NAT. ● 138

Muretto Back2Back\*  
 Tessera - Chip 14,8x2,8 (5<sup>13/16</sup>"x1<sup>1/8</sup>")



30x30 (11<sup>13/16</sup>"x11<sup>13/16</sup>")  
**E1VM M305H0** WHITE NAT. ● 130  
**E1VN M305H1** BEIGE NAT. ● 130  
**E1VP M305H8** GREY NAT. ● 130

\* Su rete in fibra - On fibre mesh backing - Sur filet en fibre de verre  
 Auf Glasfasernetz - Sobre malla de fibra - На волоконной сетке

## Back

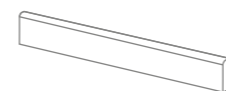
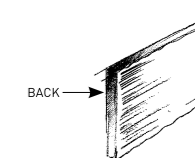

**BATTISCOPA - SKIRTING**  
 7,5x60 (2<sup>15/16</sup>"x23<sup>5/8</sup>")  
 Pcs. Box 15 - Ml. x Box 9  
**E1Y9 875H0R** BACK WHITE NAT. RETT. ● 16  
**E1YA 875H1R** BACK BEIGE NAT. RETT. ● 16  
**E1YC 875H8R** BACK GREY NAT. RETT. ● 16

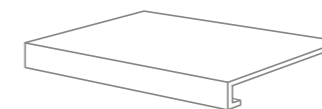

**GRADONE - STEP**  
 33x60x3,2x3,2 (12<sup>15/16</sup>"x23<sup>5/8</sup>"x1<sup>1/4</sup>"x1<sup>1/4</sup>")  
 Pcs. Box 4 - Ml. x Box 2,40  
**E85P CR5H0RG** BACK WHITE NAT. RETT. ● 89  
**E85Q CR5H1RG** BACK BEIGE NAT. RETT. ● 89  
**E85R CR5H8RG** BACK GREY NAT. RETT. ● 89

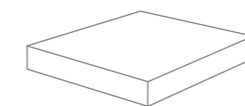

**ANGOLARE DX / SX - CORNER TILE DX / SX**  
 33x33x3,2x3,2 (12<sup>15/16</sup>"x12<sup>15/16</sup>"x1<sup>1/4</sup>"x1<sup>1/4</sup>")  
 Pcs. Box 2 - Ml. x Box 0,66  
**E857 A5H0RC** BACK WHITE NAT. RETT. ● 96  
**E858 A5H1RC** BACK BEIGE NAT. RETT. ● 96  
**E859 A5H8RC** BACK GREY NAT. RETT. ● 96

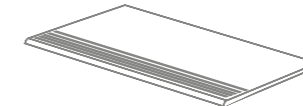

**GRADINO - STAIR TREAD**  
 33x60 (12<sup>15/16</sup>"x23<sup>5/8</sup>")  
 Pcs. Box 6 - Ml. x Box 3,60  
**E85Y 715H0RG** BACK WHITE NAT. RETT. ● 56  
**E85Z 715H1RG** BACK BEIGE NAT. RETT. ● 56  
**E860 715H8RG** BACK GREY NAT. RETT. ● 56

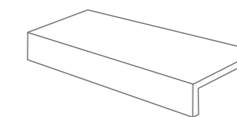

**ELEMENTO A "L" - L SHAPED PIECE**  
 15x60x4,5 (5<sup>7/8</sup>"x23<sup>5/8</sup>"x1<sup>3/4</sup>")  
 Pcs. Box 4 - Ml. x Box 2,40  
**E86A 995H0R** BACK WHITE NAT. RETT. ● 37  
**E86C 995H1R** BACK BEIGE NAT. RETT. ● 37  
**E1YK 995H8R** BACK GREY NAT. RETT. ● 37

# Back2Back



Dry - Pressed Ceramic Tiles ISO 13006 Annex G - UNI EN 14411 Annex G - Bia UGL

<b>CARATTERISTICHE TECNICHE</b> Technical Features - Caracteristiques Techniques - Technische Eigenschaften Technische Eigenschaften - Características Técnicas - Технические Характеристики		<b>NORMA</b> Standard - Norme Norm - Norma - Норма	<b>VALORI</b> Value - Valeur Vorgabe - Valor - Средние	
	<b>PLANARITÀ</b> Flatness - Planéité - Ebenflächigkeit - Planaridad - Плоскостность	UNI EN ISO 10545/2	± 0,26% / ± 1,5 mm	
		ASTM C485 CALIBRATED ± 0,75% (MAX ± 0,09 in)	-	
		ASTM C485 RECTIFIED ± 0,40% (MAX ± 0,05 IN-SIZE ≤ 60 cm) (MAX ± 0,07 IN-SIZE > 60 cm)	± 0,25%	
	<b>ASSORBIMENTO D'ACQUA (VALORE MEDIO IN %)</b> Water absorption (Average value expressed in %) - Absorption d'eau (Valeur moyenne en %) Wasseraufnahme (Durchschnittswert in %) - Absorción de agua (Valor medio en %) Поглощение воды	UNI EN ISO 10545/3 ≤ 0,5 %	CONFORME	
		ASTM C373	COMPLIANT	
	<b>RESISTENZA ALLA FLESSIONE</b> Modulus of rupture - Resistance a la flexion - Biegefestigkeit Resistencia a la flexion - Прочность на изгиб	UNI EN ISO 10545/4	≥ 50 N/mm <sup>2</sup>	
		<b>FORZA DI ROTTURA</b> Breaking strength - Résistance à la rupture - Bruchlast - Resistencia a la rotura - Разрывное усилие	UNI EN ISO 10545/4	≥ 2000 N
	<b>RESISTENZA AL GELO</b> Frost resistance - Résistance au gel - Frostbeständigkeit Resistencia a las heladas - Морозостойкость	UNI EN ISO 10545/12	CONFORME	
		ASTM C1026	UNAFFECTED	
	<b>RESISTENZA CHIMICA</b> <b>AD ALTE E BASSE CONCENTRAZIONI DI ACIDI E BASI</b> Chemical resistance to high and low acid and basic concentrations Résistance chimique aux hautes et basses concentrations d'acides et de bases Chemikalienfestigkeit bei hohen und niedrigen Konzentrationen von Säuren und Basen Resistencia química con concentraciones altas y bajas de ácidos y bases Химическая стойкость к высоким и низким концентрациям кислот и щелочей	UNI EN ISO 10545/13	UA - ULA - UHA	
		ASTM C-650	UNAFFECTED	
	<b>RESISTENZA ALLE MACCHIE</b> Stain resistance - Résistance aux taches - Fleckenbeständigkeit Resistencia a las manchas - Стойкость к образованию пятен	UNI EN ISO 10545/14	5	
		CTI 81-7D	NO EVIDENT VARIATION	
	<b>COEFFICIENTE DI ATTRITO</b> Slip resistance - Coefficient de glissement - Rutschfestigkeit Barfußbereich Coeficiente de atrito medio - Коэффициент трения		<b>NAT.</b>	<b>LAPP.</b>
		DIN 51130	R10	-
		DIN 51097	B (A+B)	-
		ANSI A 137.1- 2012 DCOF (SECTION 9.6)	WET ≥ 0,42	-
		B.C.R.A.	≥ 0,40	-

Per maggiori chiarimenti sui dati tecnici e sulla garanzia consultare il catalogo generale in vigore. - For further information on technical specifications, please consult our up-dated general catalogue. - Pour toutes informations supplémentaires sur les données techniques et sur les garanties, veuillez consulter le catalogue general en vigueur. - Für weitere Informationen über technische Daten und Garantie beziehen sie sich bitte auf den aktuellen Gesamtkatalog. - Para ultteriores informaciones sobre los datos técnicos y la garantía, vease el catalogo general en vigor. - Более подробную информацию о технических данных и гарантии смотрите в действующем сводном катал.

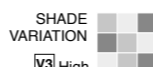

Formato Size Format Format Татаño Формат cm	Spessore Thickness Épaisseur Stärke Espesor Толщина mm	Pz. x Mq. Pieces x Sqm Pcs / M <sup>2</sup> Stk. x Qm Pzs x Mc. Шт x Кв.М.	Pz. x Scat. Pieces x Box Pcs / Bte Stk. x Krt. Pzs x Caja Шт x Кор.	Mq. x Scat. Sqm x Box M <sup>2</sup> / Bte Qm x Krt. Mc. x Caja Кв.М. x Кор.	Peso x Scat. Weight x Box Poids / Bte Gewicht x Krt. Peso x Caja Вес x Кор. Kg	Scat. x Pal. Boxes x Pal. Bte / Pal. Krt. x Pal. Cajas x Pal. Кор. x Подд.	Mq. x Pal. Sqm x Pal. M <sup>2</sup> / Pal. Qm x Pal. Mc. x Pal. Кв.М x Подд.	Peso x Pal. Weight x Pal. Poids / Pal. Gewicht x Pal. Peso x Pal. Вес x Подд. Kg
60x120 Naturale - Lappato	10	1,39	2	1,440	34,23	36	51,84	1232
20x120 Naturale	10	4,17	4	0,960	23,50	40	38,40	940
60x60 Naturale - Lappato	10	2,78	3	1,080	26,50	40	43,20	1060
30x60 Naturale	10	5,56	6	1,080	26,50	40	43,20	1060
30x30 Mosaico	10	11,11	5	0,450	10,80	60	27,00	648
30x30 Muretto	10	11,11	5	0,450	10,80	-	-	-



A Brand of Emiceramica S.r.l. a socio unico



<b>Ergon is a brand of Emilceramica S.r.l. a socio unico</b>	<b>Sede Commerciale/ Amministrativa</b>
emilgroup.it/ergon emilgroup.it	Via Ghiarola Nuova, 29 - 41042 Fiorano Modenese (Mo) Italy T +39 0536 835111 - info@emilceramicagroup.it F (Italy) +39 0536 835958 - (Export) +39 0536 835490